



ISSN: 3081-0663

Journal of Multidisciplinary Research for SMET

Volume (1), Issue (2), 2025



The China-ASEAN Expo as a Driver of Digital Service Exports: A Mechanism-Based Review

Liu Zhuguang¹, Htet Thiri Naing²

¹Liu Zhuguang, Professor, School of Economics, Guangxi University, 100 Daxue East Road, Nanning, Guangxi, China.

Email: zhuguangl@126.com

²Htet Thiri Naing, Research Scholar, School of Economics, Guangxi University, 100 Daxue East Road, Nanning, Guangxi, China.

Email: htetthiri821999@gmail.com

Abstract

The China-ASEAN Expo (CAEXPO) has become a pivotal platform in facilitating digital service trade between China and ASEAN nations, fostering regional integration and economic cooperation. This review explores the mechanisms through which CAEXPO drives digital service export growth, focusing on four key processes: policy transmission, platform empowerment, enterprise upgrading, and scale promotion. These mechanisms interact in a feedback loop that reduces trade barriers, enhances efficiency, and encourages technological innovation. By leveraging theories such as the trade gravity model, regional integration theory, transaction cost theory, and competitive advantage theory, this paper examines how CAEXPO aligns with regional trade agreements like RCEP to promote digital service exports. It also discusses the impacts of CAEXPO's platform on reducing transaction costs and fostering innovation through cross-border collaboration. The findings highlight the significant role of CAEXPO in shaping digital trade dynamics in ASEAN and provide valuable insights into how regional trade platforms can foster growth in the digital economy. This paper contributes to the understanding of how institutional collaboration and technological empowerment can accelerate the globalization of digital services.

Keywords: China–ASEAN Expo (CAEXPO); Digital Service Trade; Regional Economic Integration; Platform Economics; ASEAN Cooperation

1. Introduction

The China-ASEAN Expo (CAEXPO), established in 2004, has emerged as a cornerstone of economic collaboration between China and the Association of Southeast Asian Nations (ASEAN). As regional integration accelerates, CAEXPO plays a pivotal role in fostering trade, investment, and technological exchanges between these nations. Over the years, the Expo has evolved to support the growing importance of the digital economy, positioning itself as a crucial platform for facilitating digital service exports.

As digitalization continues to reshape global trade, developing economies increasingly view digital platforms as catalysts for inclusive growth and competitiveness. Similar to how digital transformation has been linked to development outcomes in other emerging contexts (Paing, 2025), the ASEAN region's digital trade expansion represents both an opportunity and a structural challenge. Within this landscape, CAEXPO serves as a critical institutional mechanism for translating digital growth into sustained regional integration.

This transformation is particularly notable as the region shifts from traditional goods trade to include a burgeoning digital services sector encompassing cloud computing, e-commerce, software development, and digital content creation. The growing role of digital services has been facilitated by the establishment of regional frameworks like



This article is published under the terms of the Creative Commons Attribution 4.0 International License (CC BY 4.0).

the China-ASEAN Free Trade Area (CAFTA) and the Regional Comprehensive Economic Partnership (RCEP), both of which aim to streamline policies and promote integration. As digital services become a significant contributor to economic growth in ASEAN, platforms like CAEXPO have adapted to meet the evolving demands of this new economic landscape.

This paper aims to explore the mechanisms through which CAEXPO drives digital service export growth. At the heart of this process are four key mechanisms: policy transmission, platform empowerment, enterprise upgrading, and scale promotion. These mechanisms are not isolated but work together in a feedback loop, reducing barriers, enhancing trade facilitation, and fostering innovation. Policy transmission through CAEXPO facilitates the alignment of regional trade policies, particularly those related to digital services, allowing for smoother cross-border transactions. Platform empowerment, through both physical and digital platforms, significantly reduces transaction costs and accelerates market access for businesses. The Expo also plays a key role in enterprise upgrading, encouraging technological collaboration and innovation to enhance the competitive edge of participating companies. Furthermore, CAEXPO's scale promotion mechanism facilitates the aggregation of industries and enterprises, expanding market reach and strengthening trade flows.

By examining the underlying theories such as the trade gravity model, regional integration theory, transaction cost theory, and competitive advantage theory, this review aims to deepen our understanding of how CAEXPO's four mechanisms interact to drive digital trade and economic integration. The paper highlights how institutional collaboration and technological empowerment through CAEXPO contribute to the growth of digital service exports and the wider ASEAN digital economy. It also discusses the broader implications for regional trade facilitation and offers insights into how regional platforms can be leveraged to support the development of the digital economy.

2. Methodology

Following the structured search approach commonly employed in recent bibliometric reviews published in JMR-SMET (Min & Liana, 2025), this study systematically analyzed literature on the China-ASEAN Expo, digital service trade, and the relevant theoretical frameworks. The literature search was conducted using academic databases including the China National Knowledge Infrastructure (CNKI), Web of Science, and Scopus. The search scope primarily covered the period from 2000 to 2024, with a focus on publications following the establishment of CAEXPO in 2004 to capture its evolving role. The inclusion criteria prioritized peer-reviewed journal articles, official reports from international organizations (e.g., World Bank, ASEAN) and CAEXPO authorities, and seminal books in the fields of international trade and economic theory. Keywords included 'China-ASEAN Expo,' 'digital service exports,' 'regional integration,' 'transaction cost,' 'competitive advantage,' and 'trade gravity model,' among others."

3. Literature Review

The analysis of the China-ASEAN Expo (CAEXPO) and its impact on digital service exports is grounded in several key theoretical frameworks that explain the mechanisms driving its effectiveness. These frameworks include regional integration theory, transaction cost theory, trade gravity model, and competitive advantage theory. Each of these theories offers a distinct perspective on how CAEXPO facilitates trade and supports the export of digital services within ASEAN.

Regional Integration Theory, as outlined by (BALASSA, 1961), focuses on the role of trade agreements and institutional collaboration in reducing trade barriers and fostering economic integration. Balassa's stages of regional economic integration theory suggests that free trade agreements (FTAs), such as CAFTA and RCEP, significantly reduce trade barriers through policy coordination and harmonization of rules. In the context of digital trade, this theory has evolved, as evidenced by (Zhaokun & Wensu, 2024), who found that aligning digital rules through CAFTA reduced service trade costs by 18%. The China-ASEAN Expo serves as a crucial platform for accelerating the implementation of such policies, particularly through mechanisms like high-level forums and mutual recognition workshops. These institutional efforts help ASEAN countries localize the RCEP digital provisions, thereby enhancing cooperation in digital service trade. Studies, such as those by (Yuchang, 2022) and (Huajun et al., 2024), highlight that institutional arrangements in CAEXPO significantly improve regional value chain coordination.

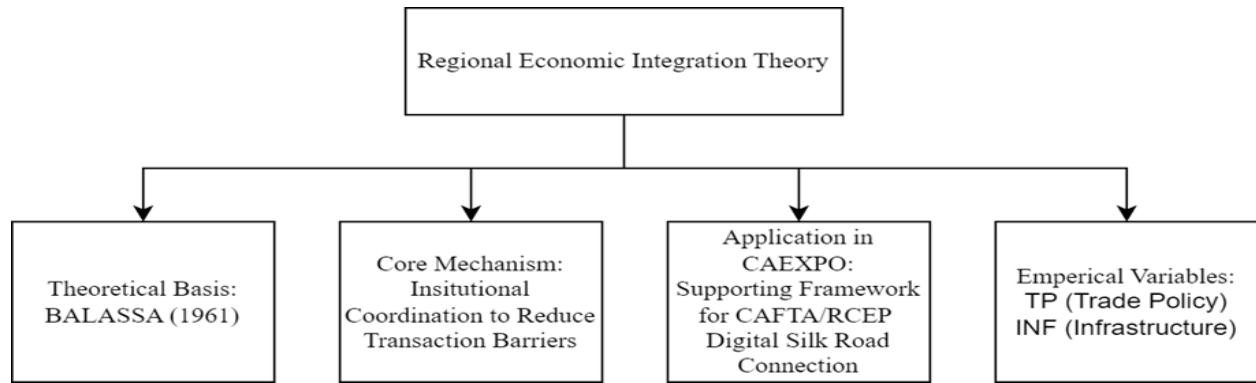

Figure 3.1. Conceptual framework of regional economic integration theory and its application to CAEXPO.

Transaction Cost Theory, introduced by (Williamson, 1981), helps explain the value-creating mechanisms of the CAEXPO platform by reducing transaction costs. Transaction costs, such as information search costs and negotiation expenses, are significant barriers to trade, particularly in the digital services sector. The Expo addresses these challenges by offering a platform where businesses can efficiently match with reliable partners, share information, and negotiate agreements in a streamlined manner. Research by Ma Tao et al. (2022) demonstrated that CAEXPO’s cloud-based platform and intelligent matching system reduced information search costs by 47%, thus lowering transaction costs for enterprises. This feature, along with the Expo's 365-day online exhibition hall, breaks the time and space limitations of traditional expos, making trade more efficient. According to the World Bank (2023), SMEs in ASEAN have reduced their average entry time to the Chinese market from 14 months to just 5 months using CAEXPO.(Yubiao & Jianghai, 2019) also found that CAEXPO’s platform significantly reduces trust-building barriers in cross-border transactions, particularly for digital services. Furthermore, the Expo’s credit endorsement mechanism has increased contract fulfillment rates to 92%, validating (North, 1990) core proposition that institutions reduce transaction uncertainty. This helps build trust in digital services, offering a new perspective on trust-building mechanisms in the digital age.

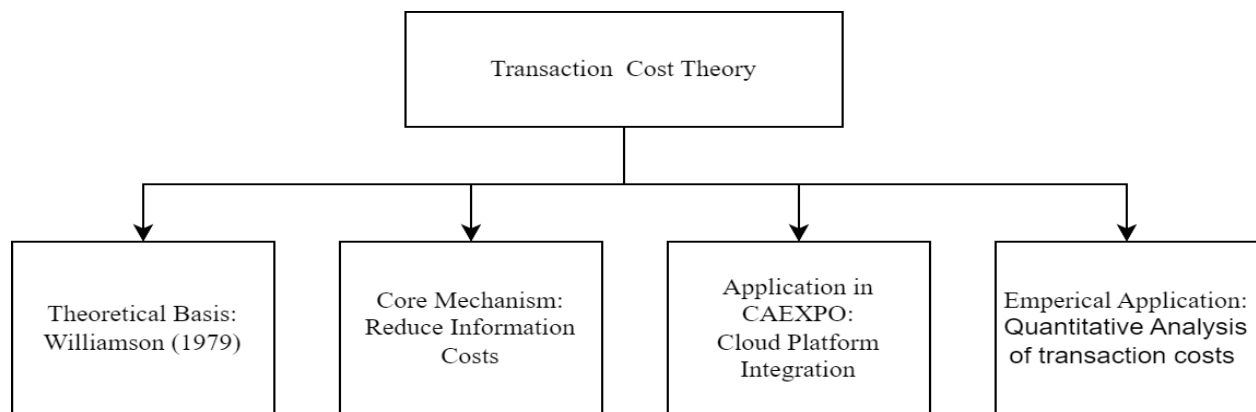

Figure 3.2. Conceptual framework of transaction cost theory and its application to CAEXPO.

The Trade Gravity Model, originally developed by (Tinbergen, 1963) and refined by (Anderson & van Wincoop, 2003), provides another lens to analyze CAEXPO’s impact. The model suggests that bilateral trade is positively related to the economic size (GDP) of trading partners and negatively correlated with geographical distance. In the case of CAEXPO, the platform effectively reduces trade distance by providing a space for both physical and digital exchanges between China and ASEAN countries. By lowering transaction costs and providing a direct link for

businesses, CAEXPO makes it easier for enterprises to engage in digital service trade across borders. (Haodong et al., 2020) found that CAEXPO plays a key role in reducing the psychological barrier of trade distance, thus making it more efficient. Moreover, (Min, 2024) emphasized that the low transportation cost attribute of the digital economy further strengthens this effect.

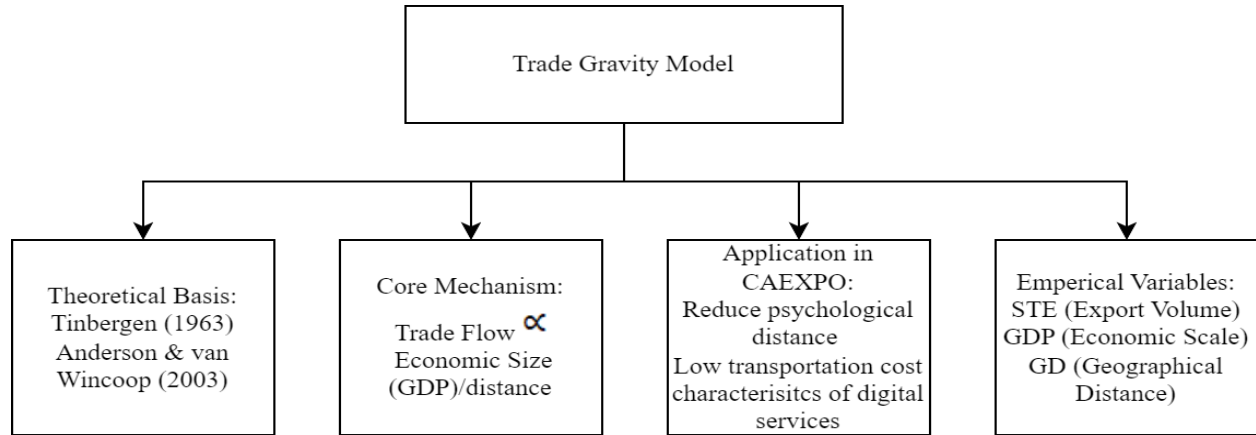

Figure 3.3. Conceptual framework of trade gravity theory and its application to CAEXPO.

Finally, Competitive Advantage Theory, developed by (Porter, 1990), explains how firms and countries gain a competitive edge in the global market through innovation, technological development, and strategic collaboration. CAEXPO plays a significant role in enterprise upgrading by promoting technology spillovers and enabling collaboration between businesses, governments, and universities. This interaction fosters technological development and innovation, which enhances the competitiveness of firms. Through CAEXPO’s exhibitions and technical matchmaking sessions, participating enterprises can access cutting-edge technologies, enhance their service offerings, and improve their value proposition. (Xinran, 2018) observed that CAEXPO has driven technology diffusion through projects like the China-ASEAN Technology Innovation Enhancement Plan, significantly boosting the capabilities of participating enterprises. Additionally, (Wei et al., 2021) proposed the "service trade value chain upgrade" path, which is actively supported by CAEXPO. This aligns with Porter’s "diamond model", which emphasizes the role of factors like demand conditions, related industries, and institutional support in enhancing competitive advantage.

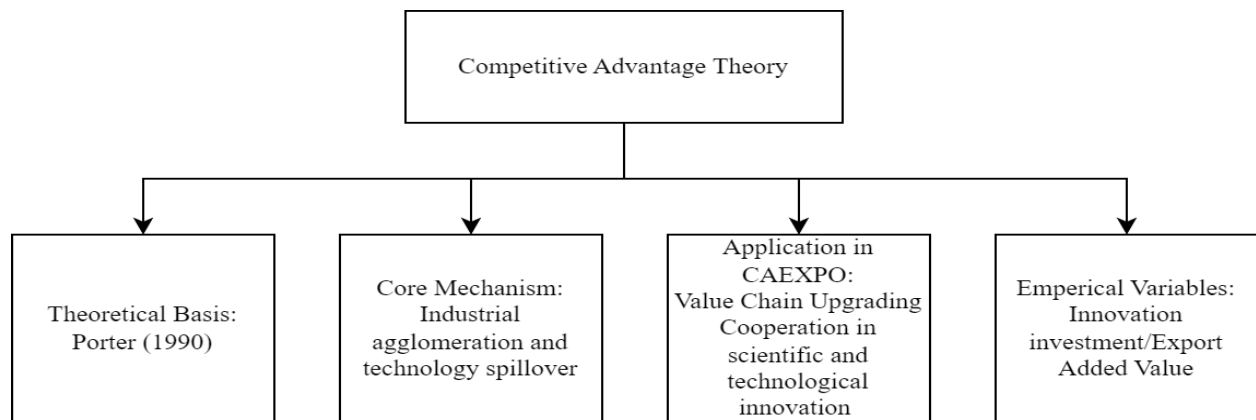

Figure 3.4. Conceptual framework of competitive advantage theory and its application to CAEXPO.

Taken together, these four theories provide a coherent and interconnected analytical foundation for understanding CAEXPO’s role in driving digital service trade. At the macro level, Tinbergen’s trade gravity model establishes the spatial and quantitative basis for cross-border trade by linking economic scale, distance, and policy variables to trade flows. Moving to the meso level, Balassa’s regional integration theory explains how institutional coordination and policy harmonization—through frameworks such as CAFTA and RCEP—reduce structural barriers and enable regional connectivity. At the micro level, Williamson’s transaction cost theory illuminates how platform efficiency and digital infrastructure minimize information and negotiation costs, fostering smoother trade interactions. Finally, at the long-term level, Porter’s competitive advantage theory captures the innovation-driven processes through which enterprises enhance technological capabilities, climb the value chain, and sustain competitiveness. The integration of these perspectives yields a multi-level framework that links macro-institutional dynamics, meso-level policy mechanisms, and micro-enterprise capabilities within a single explanatory model.

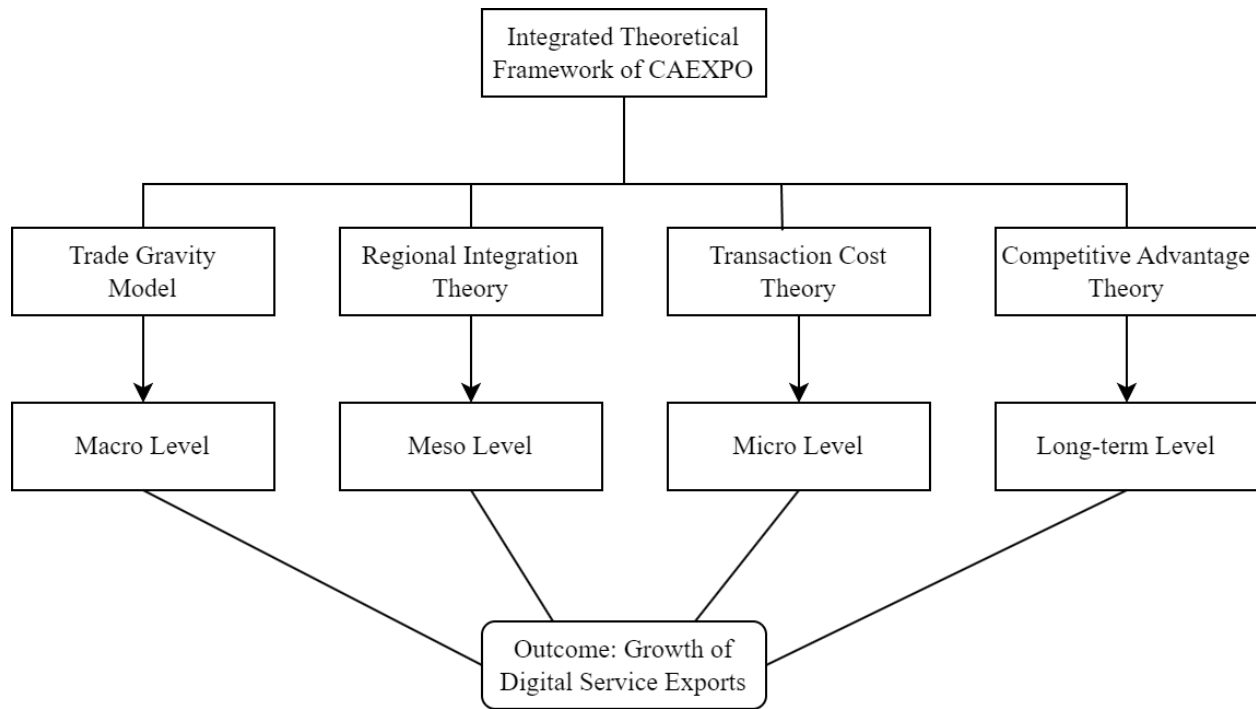

Figure 3.5. Integrated multi-level theoretical framework of CAEXPO.

This synthesis not only clarifies how CAEXPO functions simultaneously as a policy coordination hub, digital platform, and enterprise catalyst, but also provides the theoretical basis for the mechanisms analyzed in subsequent sections. The following table and figures present this integrated framework, showing how the four classical theories interact across analytical levels and operational pathways.

Table 3.1 Integrated theoretical interaction framework explaining CAEXPO’s mechanisms.

Theoretical lens	Primary focus	Function within the integrated system	Cross-linkages with other theories	CAEXPO application
Trade Gravity Model (Tinbergen, 1963)	Spatial–quantitative determinants of trade (GDP, distance, policy variables)	Establishes baseline “trade field” that defines constraints and opportunities	Provides macro context in which institutional integration and firm upgrading operate	Sets the external envelope for China–ASEAN digital service flows
Regional Integration Theory (Balassa, 1961)	Institutional coordination and rule harmonization	Reconfigures the gravity field by reducing effective distance through common policies (CAFTA, RCEP)	Builds the policy space exploited by transaction-cost reduction and innovation	Converts policy frameworks into actionable cooperation mechanisms via CAEXPO forums
Transaction Cost Theory (Williamson, 1979)	Governance efficiency and information cost reduction	Activates the integrated field through platform intermediation that lowers search and enforcement costs	Translates institutional rules into real market interactions; links meso policy to micro enterprise	Cloud CAEXPO and digital matchmaking reduce coordination and trust-building costs
Competitive Advantage Theory (Porter, 1990)	Innovation, clustering, and capability upgrading	Reinforces the system through technological learning and value-chain ascent	Feeds back into the gravity model (expanding economic mass) and motivates deeper integration	Enterprise upgrading and technology diffusion at CAEXPO enhance long-term competitiveness

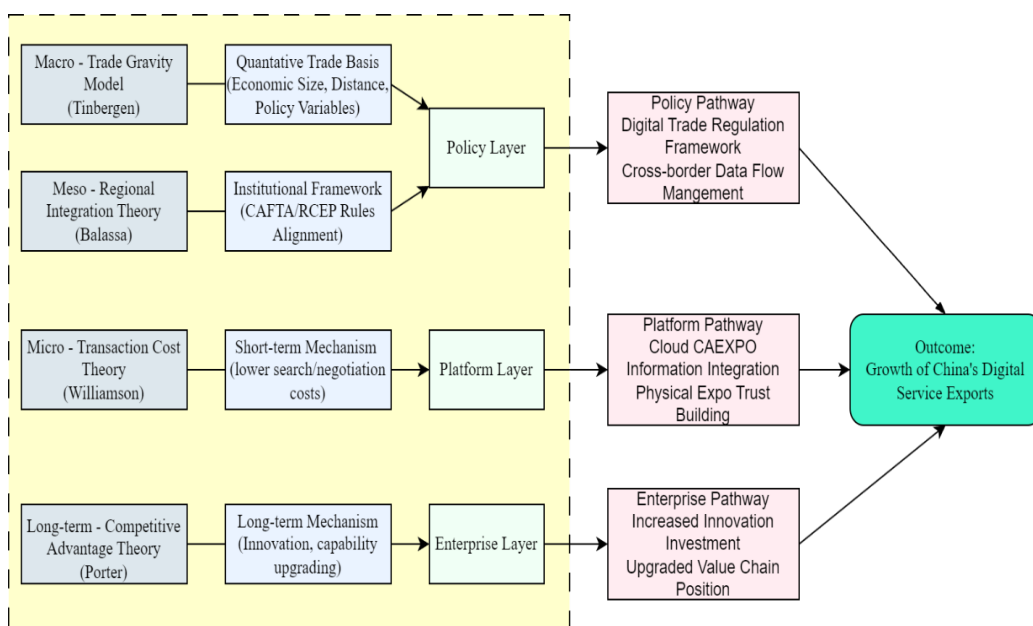

Figure 3.6. Operational mechanism framework linking theoretical foundations to CAEXPO pathways.

4. Mechanisms Driving Digital Service Exports via CAEXPO

The China-ASEAN Expo (CAEXPO) plays a critical role in driving digital service exports within the ASEAN region by leveraging several key mechanisms that reduce trade barriers and foster cooperation. These mechanisms: policy transmission, platform empowerment, enterprise upgrading, and scale promotion operate in synergy to create an environment conducive to digital service trade.

4.1 Policy Transmission Mechanism

The policy transmission mechanism is a central feature of CAEXPO, enhancing the facilitation of digital service trade by harmonizing trade rules and regulatory frameworks within the ASEAN region. Regional integration theory (BALASSA, 1961) highlights the importance of policy coordination and institutional synergy in reducing trade barriers. CAEXPO facilitates the effective transmission of RCEP’s digital provisions, which are pivotal for promoting seamless cross-border digital trade. According to (Zhaokun & Wensu, 2024), the e-commerce provisions outlined in Chapter 12 of RCEP have a tangible trade effect through CAEXPO's policy coordination platform. Specifically, CAEXPO has facilitated a "bilateral policy dialogue – technical standard mutual recognition – regulatory sandbox trial" system, which effectively reduces institutional transaction costs for digital services. The Expo’s role in policy transmission was notably demonstrated in the 2023 digital economy ministerial forum between China and Singapore, where mutual recognition of cross-border electronic signatures was achieved, aligning with RCEP’s "Paperless Trade" rules (Zhaokun & Wensu, 2024). This alignment shortened contract effectiveness cycles from an average of 15 days to just 3 days, driving a 23% increase in the export of technical services. Additionally, Ju Jiandong (2022) highlighted the multiplier effect of rule alignment, showing that every 10% increase in institutional facilitation can raise the likelihood of digital service contract signings by 15.7 percentage points, particularly for high-value-added sectors like cloud services and digital content.

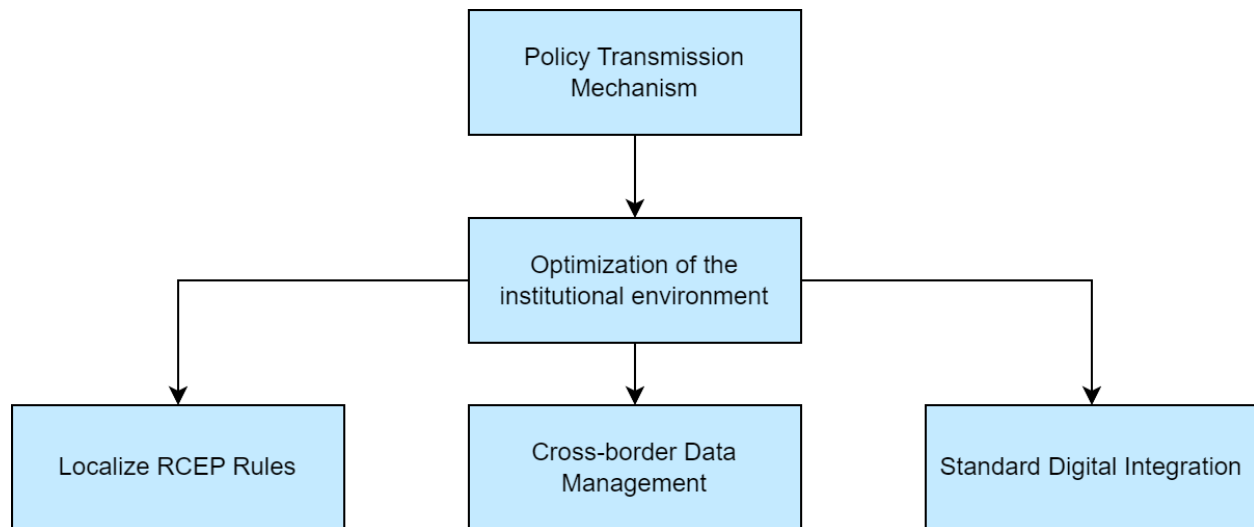

Figure 4.1 Structure of the policy transmission mechanism under CAEXPO.

4.2 Platform Empowerment Mechanism

The platform empowerment mechanism significantly reduces the transaction costs of digital service trade through CAEXPO’s dual physical-virtual platform integration. According to transaction cost theory (Williamson, 1981), CAEXPO reduces transaction costs by providing a centralized platform for information exchange, matchmaking, and partner collaboration. The cloud-based CAEXPO platform, which integrates physical and virtual

elements, offers a more efficient information exchange paradigm that reduces information search costs by 47%, as demonstrated by (Yubiao & Jianghui, 2019) in their study on the platform economy's impact on service trade exports. This mechanism is particularly impactful in sectors like software services and digital content, where transaction costs related to finding the right partners can be high. The AI-based demand-supply matching system further compresses traditional matchmaking cycles from 20 days to under 72 hours, which accelerates business interactions and contract finalization. This efficiency leap is exemplified by enterprises such as those from Malaysia, which, through real-time updates on the product database and credit certification system, experienced a contract fulfillment rate of 92%, far above the industry average (ASEAN Digital Economy Committee, 2023). Additionally, (CNNIC, 2023) indicated that the integration of online signing, cross-border settlement, and digital customs clearance functions reduced the transaction cycle for digital services from 45 days to just 8 days, contributing to a 34% annual export growth rate for Singaporean tech companies that utilized full-process services. This demonstrates the significant role of digital platform penetration in driving trade participation, validating (van Dijk, 2020) theory on the digital divide.

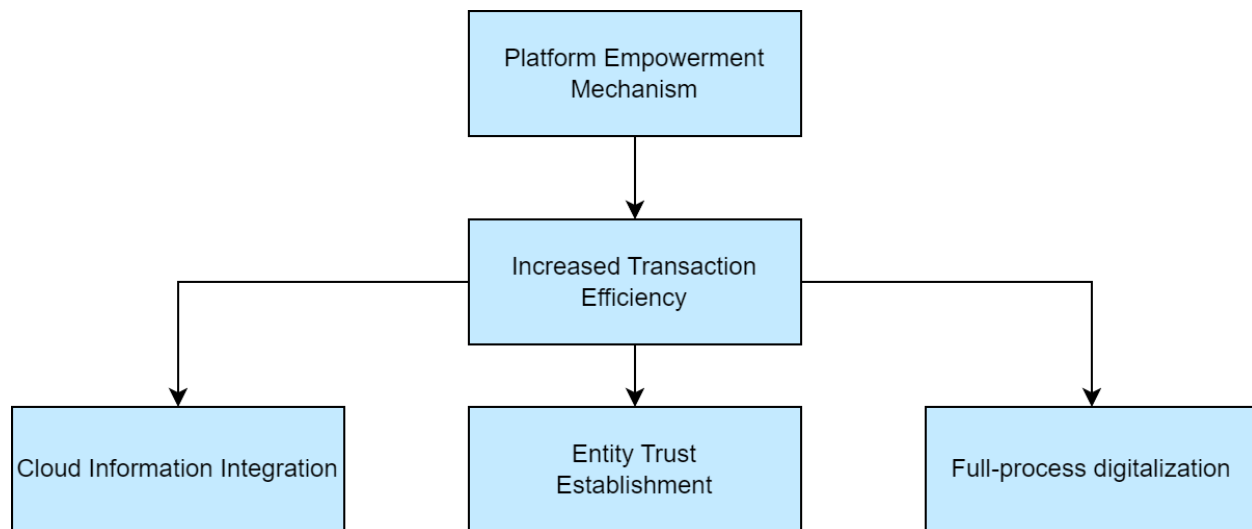

Figure 4.2 Structure of the platform empowerment mechanism under CAEXPO.

4.3 Enterprise Upgrading Mechanism

The enterprise upgrading mechanism facilitated by CAEXPO is a key driver of digital service export growth. According to Porter's (1990) theory of competitive advantage, the Expo encourages technological innovation and knowledge spillovers, which are essential for enhancing a firm's global competitiveness. CAEXPO fosters collaboration between businesses, universities, and government agencies, creating opportunities for technology transfer and R&D collaboration. Studies by (Wei et al., 2021) verified through micro-enterprise panel data in their study that the knowledge spillover elasticity coefficient of enterprises participating in the technology matching at the Expo reached 0.78, which increased the new quality productivity of digital services by more than three times compared to the traditional trade models. This was exemplified at the 2023 Expo, where Huawei partnered with nine ASEAN countries to establish a joint R&D center, reducing the cloud service architecture iteration cycle for Vietnam's FPT Group by 60%, while boosting their solution prices to China by 28% (ASEAN Technology Agency Report, 2023). This collaboration aligns with Lin Guijun's (2022) research on digital service upgrades within the Asia-Pacific value chain, where companies in CAEXPO's ecosystem showed an average improvement of 0.47 standard deviations in their value chain positioning. Notably, Chinese digital content enterprises in the Expo developed a full value chain from content creation to localization and cross-border distribution, increasing their value-added rate in ASEAN from 35% in 2019 to 61% in 2023. The non-linear

relationship between R&D investment and patent applications further corroborates Porter's diamond model, showing that enterprises with high R&D intensity and patent filings experience a 43% premium in digital service exports (China National Intellectual Property Administration Blue Book, 2024).

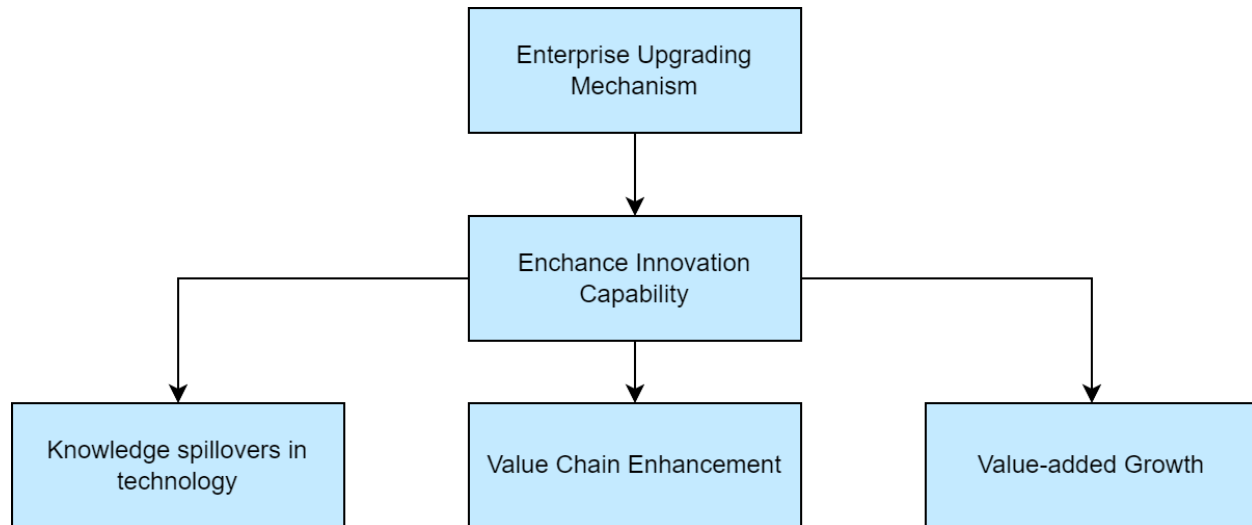

Figure 4.3 Structure of the enterprise upgrading mechanism under CAEXPO.

4.4 Scale Promotion Mechanism

The scale promotion mechanism amplifies the reach of Chinese digital service enterprises in ASEAN through market aggregation. As explained by the trade gravity model (Tinbergen, 1963), CAEXPO's ability to bring together large numbers of enterprises significantly enhances trade flows. (Haodong et al., 2020) found that a 10% increase in the number of participating enterprises leads to a 2.3% rise in digital service exports, particularly in knowledge-intensive sectors like digital healthcare and cloud services. The Expo's industry-specific exhibitions and intelligent matchmaking system facilitate the aggregation of stakeholders from diverse sectors, expanding market reach and creating a network effect that drives increased trade volume. In 2023, the Digital Economy Special Exhibition Area showcased a complete ecosystem, from 5G infrastructure to AI applications, attracting 78 ASEAN digital giants like GoTo and Grab, leading to \$800 million in contracts signed in just one day (Expo Achievement Report). The dual-layer structure of CAEXPO, featuring national theme pavilions and industry vertical areas, further enhances the scale economy effect by increasing market access. According to (Krugman, 1991) new economic geography theory, CAEXPO expanded enterprise market reach by 15 times, with first-time exhibitors gaining an average of 23.6 potential clients through the exhibitor database smart push system. Participating enterprises with over three years of consecutive participation saw a 34.7% compound annual growth rate in their ASEAN order volume, validating Tinbergen's scale gravity multiplier effect (Haodong et al., 2020).

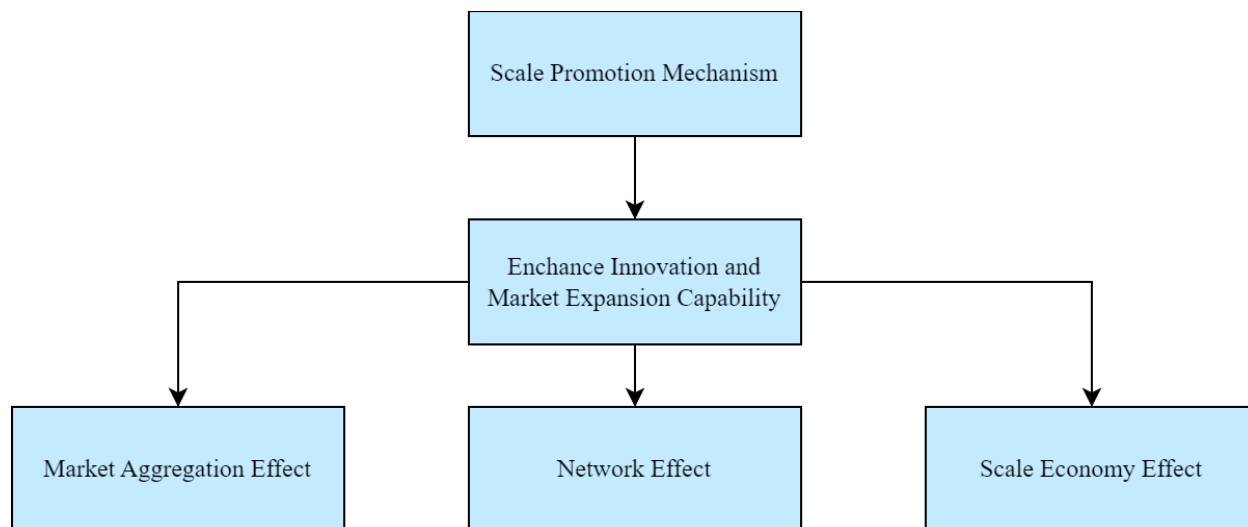

Figure 4.4 Structure of the scale promotion mechanism under CAEXPO.

5. Discussion

The China–ASEAN Expo (CAEXPO) represents a unique institutional platform through which regional cooperation and digital trade facilitation are operationalized. The mechanisms reviewed in this study, policy transmission, platform empowerment, enterprise upgrading, and scale promotion-do not function in isolation but interact dynamically, reinforcing one another in a cumulative cycle. This synergy explains CAEXPO’s effectiveness in promoting digital service exports and advancing regional economic integration (Qun, 2023; Suh & Roh, 2023).

At the institutional level, the policy transmission mechanism provides the foundation for this interconnected system. By translating regional trade agreements such as the Regional Comprehensive Economic Partnership (RCEP) into actionable frameworks, CAEXPO reduces regulatory and procedural barriers, thereby improving predictability for digital service providers (Qun, 2023; Tao & Zhengyang, 2018). Once policy alignment is achieved, it sets the stage for platform empowerment, which directly lowers transaction costs and enhances connectivity through digitalization. A more efficient platform, in turn, facilitates enterprise upgrading, as firms operating in this environment can leverage information sharing, technological exchange, and knowledge spillovers to improve competitiveness. Finally, the aggregation of participants and the resulting scale promotion mechanism amplify these effects by expanding market access and attracting new entrants, which further drives policy convergence and institutional learning. In this way, the four mechanisms form a self-reinforcing loop that transforms CAEXPO from a conventional trade fair into a continuous driver of digital economic cooperation.

CAEXPO’s evolution also reflects a broader transformation in regional trade governance. Over time, the Expo has expanded beyond its initial commercial purpose to become a semi-formal institutional platform hosting ministerial dialogues and intergovernmental forums alongside its exhibitions (Friedrich-Ebert-Stiftung, 2021). Reports from both the CAEXPO Secretariat and ASEAN officials describe the event as “a premier cross-border business platform” that bridges state-led cooperation and enterprise participation (Yu & Wei, 2023). The establishment of the “Cloud CAEXPO” and digital economy exhibition zones since 2020 further illustrates its dual role as both a policy coordination hub and an innovation catalyst (Xu et al., 2024). This hybrid nature enables CAEXPO to function simultaneously as a mechanism for top-down policy alignment and bottom-up market integration, turning diplomatic consensus into tangible commercial outcomes.

In comparison with other multilateral platforms, CAEXPO’s governance approach occupies an intermediate position between the EU Digital Single Market and the Asia-Pacific Economic Cooperation (APEC) digital trade initiatives. Whereas the EU’s model achieves deep integration through binding legislative instruments such as the General Data Protection Regulation (GDPR) and the Digital Services Act (European-Commission, 2015), and APEC relies on

voluntary, consensus-based cooperation under frameworks like the Cross-Border Privacy Rules (CBPR) system (APEC, 2012, 2019), CAEXPO employs a flexible, dialogue-based structure. This middle-ground design combines formal institutional continuity with adaptive experimentation, enabling China and ASEAN members to pursue regulatory convergence without the rigidity of treaty law. Scholars argue that this pragmatic hybrid structure—anchored in both policy dialogue and private-sector participation makes CAEXPO a distinctive form of governance that blends the institutional depth of the EU model with the openness and adaptability of APEC’s networked regionalism (Gao & Chen, 2025).

Theoretically, this interconnected system demonstrates how classical economic and management frameworks such as Balassa’s regional integration theory (BALASSA, 1961), Williamson’s transaction cost economics (Williamson, 1981), Porter’s competitive advantage model (Porter, 1990), and Tinbergen’s gravity model (Tinbergen, 1963) remain relevant in the digital era, albeit in new configurations. CAEXPO exemplifies how institutional coordination (Balassa) reduces the governance costs (Williamson) associated with cross-border exchanges, while technological diffusion and collaborative innovation (Porter) enhance competitiveness at both firm and national levels. The gravity effect (Tinbergen) is also evident, as the growth in the number of participants and their cumulative interactions generate increasing returns to scale. From the perspective of new institutional economics, CAEXPO functions as a repeated trust-building mechanism that lowers uncertainty and coordination costs by providing a stable environment for long-term cooperation (Qun, 2023). Simultaneously, through the lens of platform economics, the Expo operates as a multi-sided platform connecting governments, enterprises, and investors, generating network effects that enhance overall value creation (Rochet & Tirole, 2003). As (Evans & Schmalensee, 2017) suggest, such platforms reduce search and negotiation costs while amplifying participation-based utility, a principle reflected in CAEXPO’s expanding online ecosystem.

Beyond its theoretical implications, CAEXPO’s experience provides insight into the governance of regional digital trade. Its hybrid model—combining government-led institutional coordination with market-driven innovation, offers a distinctive contrast to other global platforms. While the China International Import Expo emphasizes trade liberalization and the EU Digital Single Market focuses on rule harmonization, CAEXPO integrates both functions by coupling intergovernmental dialogue with digital-market experimentation (European-Commission, 2015). This dual role allows governments to test regulatory approaches—such as electronic signature recognition or cross-border data governance while enterprises engage in technological showcasing and partnership building. Consequently, CAEXPO operates not only as a marketplace for goods and services but also as a governance laboratory where policy, technology, and commerce intersect.

Nevertheless, several challenges remain. The digital infrastructure and regulatory readiness of ASEAN members are highly uneven, with pronounced disparities between advanced economies like Singapore and emerging ones such as Myanmar and Laos. The ASEAN Digital Masterplan 2025 identifies these structural gaps, noting that broadband penetration ranges from over 90 percent in Singapore to below 40 percent in Myanmar (ASEAN, 2021). This digital divide extends beyond infrastructure to differences in legal frameworks, cybersecurity capacity, and workforce digital literacy. During the 22nd CAEXPO, ASEAN Secretary-General Dr. Kao Kim Hourn called for concerted efforts to “close the digital divide” through targeted investments in digital infrastructure and cross-border skills development (Secretariat, 2024). Scholars similarly emphasize that inclusive digital trade requires tailored policy support such as regional capacity-building programs, low-cost connectivity for small economies, and cross-border digital-skills certification to ensure that the benefits of integration are equitably distributed (ASEAN, 2021; Yuanpeng & Chaonan, 2024). Bridging these disparities is essential not only for social inclusion but also for regional competitiveness, as uneven participation weakens network efficiency and limits the collective gains of digital trade cooperation.

The need for inclusive participation in regional digital trade mirrors broader global discussions about institutional alignment and SME integration. As (Adhikary & Ghosh, 2025) observe, well-defined policy frameworks and classification systems are critical to ensuring equitable access to economic opportunities across diverse income groups. Similarly, CAEXPO’s mechanisms through harmonized trade policies, digital infrastructure, and enterprise-level capacity building help address structural disparities among ASEAN member economies, fostering inclusivity and enabling smaller enterprises to benefit from regional integration.

Taken together, these dynamics reaffirm the continued relevance of classical and contemporary theories of integration and cooperation while revealing the growing significance of hybrid institutional models in the digital age. CAEXPO demonstrates that the effectiveness of regional trade mechanisms depends not solely on formal agreements but also on their ability to adapt to technological change and engage diverse stakeholders. The Expo's platform-based design, coupled with its institutional legitimacy, suggests a new paradigm of regional cooperation in which governance flexibility and digital innovation reinforce one another. As ASEAN moves toward the implementation of the Digital Economy Framework Agreement, CAEXPO's experience offers both a conceptual framework and an operational model for building resilient, inclusive, and innovation-oriented regional digital ecosystems (Secretariat, 2024; Suh & Roh, 2023).

6. Conclusion

This review has examined the China–ASEAN Expo (CAEXPO) as a multi-dimensional institutional platform that facilitates the growth of digital service exports between China and ASEAN. Drawing on regional integration theory, transaction cost theory, competitive advantage theory, and the trade gravity model, the analysis demonstrates that CAEXPO's impact arises from the coordinated operation of four interdependent mechanisms: policy transmission, platform empowerment, enterprise upgrading, and scale promotion. Together, these mechanisms create a self-reinforcing ecosystem in which institutional alignment, digital innovation, and market expansion converge to sustain regional trade growth. The significance of CAEXPO lies not only in its role as a trade exhibition but also in its function as a long-term governance and coordination platform for regional digital economic cooperation. Its evolution illustrates how formal agreements such as the Regional Comprehensive Economic Partnership (RCEP) can be transformed into concrete outcomes when supported by a physical and digital institutional hub. By linking rule harmonization with technological integration, CAEXPO bridges the gap between policy frameworks and firm-level practice, enabling the diffusion of innovation, the reduction of transaction costs, and the expansion of trade networks. From a theoretical perspective, CAEXPO exemplifies how classical economic models can be adapted to explain emerging forms of regional cooperation in the digital era. The platform's success demonstrates that institutional innovation and technological empowerment are not separate processes but mutually reinforcing dimensions of a new digital trade paradigm. This synergy contributes to a deeper understanding of how trade facilitation, digital infrastructure, and enterprise capability interact to generate competitive advantages in global value chains. Despite these achievements, challenges remain in ensuring the inclusiveness and sustainability of CAEXPO's growth model. The uneven digital readiness of ASEAN economies, fragmented data governance regimes, and the limited participation of smaller enterprises continue to constrain the potential of the regional digital ecosystem. Addressing these disparities will require greater policy coordination, investment in digital infrastructure, and the creation of mechanisms that enable knowledge transfer and innovation diffusion across varying levels of development. Overall, the findings of this review underscore CAEXPO's strategic role in advancing China–ASEAN digital economic integration. By institutionalizing cooperation, reducing frictions, and fostering innovation, CAEXPO provides a replicable model for other regional platforms seeking to transform policy frameworks into measurable economic gains. Future research—particularly empirical analyses using firm- and industry-level data—should focus on quantifying the relative contributions of the four mechanisms and identifying pathways to enhance their effectiveness. Such work will not only deepen understanding of CAEXPO's influence but also provide evidence-based guidance for strengthening digital trade governance and promoting inclusive growth across the region.

References

- Adhikary, N., & Ghosh, A. (2025). Defining MSMEs: A Study of Global Practices for Implementation in a Nepali Context. *Journal of Multidisciplinary Research for SMET (JMR-SMET)*, 1(1), 107-114. <https://doi.org/10.64297/jmrsmet.v1i1.11>

- Anderson, J. E., & van Wincoop, E. (2003). Gravity with Gravitas: A Solution to the Border Puzzle. *American Economic Review*, 93(1), 170–192. <https://doi.org/https://doi.org/10.1257/000282803321455214>
- APEC. (2012). GLOBAL CROSS-BORDER PRIVACY RULES SYSTEM (CBPR) PROGRAM REQUIREMENTS MAP Asia-Pacific Economic Cooperation.
- APEC. (2019). CBPR policies, rules and guidelines (revised edition). Asia-Pacific Economic Cooperation.
- ASEAN. (2021). ASEAN Digital Masterplan 2025 (ADM2025) [Report].
- BALASSA, B. (1961). TOWARDS A THEORY OF ECONOMIC INTEGRATION. 14(1), 1-17. <https://doi.org/https://doi.org/10.1111/j.1467-6435.1961.tb02365.x>
- CNNIC. (2023). The 52nd Statistical Report on China’s Internet Development
- European-Commission. (2015). A Digital Single Market strategy for Europe (COM/2015/0192 final).
- Evans, D. S., & Schmalensee, R. (2017). Multi-sided Platforms. In *The New Palgrave Dictionary of Economics* (pp. 1-9). Palgrave Macmillan UK. https://doi.org/10.1057/978-1-349-95121-5_3069-1
- Friedrich-Ebert-Stiftung. (2021). China-ASEAN Information Harbor : the Digital Silk Road from Guangxi to Southeast Asia [Print]. FES Publications. <https://doi.org/urn:nbn:de:bo133-2-8374>
- Gao, X., & Chen, X. (2025). The regime complex for digital trade in Asia and China’s engagement. *Asia Europe Journal*, 23(2), 393-413. <https://doi.org/10.1007/s10308-024-00705-0>
- Haodong, L., Xiang, L., Haodi, M., & Chunyan, H. (2020). Research on the Trade Effects of China-Asean Expo: An Empirical Analysis Based on Gravity Model. *Foreign Investment in China*(12), 11-12. <https://doi.org/Cnki:Sun:Wqzg.0.2020-12-009>
- Huajun, Q., Junyan, Q., & Jun, L. (2024). Digital Trade Barriers, RTA Regulation Integration and Service Industry Value Chain Upgrading. *The World Economy Research*(02), 34-48+135-136. <https://doi.org/https://doi.org/10.13516/j.cnki.wes.2024.02.007>
- Krugman, P. (1991). Increasing Returns and Economic Geography. 99(3), 483-499. <https://doi.org/10.1086/261763>
- Min, T. (2024). Analysis of the Impact of Digital Service Levels on China-Asean Bilateral Trade. *China Business Theory*, 33(16), 66-69.
- Min, T. A. A. H. Y. H., & Liana, S. R. (2025). Global Research Trends on the Health Impact of Air Pollution: A Bibliometric Analysis of Co-authorship Networks. *Journal of Multidisciplinary Research for SMET (JMR-SMET)*, 1(1), 117-131. <https://doi.org/10.64297/jmrsmet.v1i1.13>
- North, D. C. (1990). *Institutions, Institutional Change and Economic Performance*. Cambridge University Press. <https://doi.org/https://doi.org/10.1017/CBO9780511808678>
- Paing, M. Y. (2025). The Burden of Digital Diseases in Developing Countries: A Systematic Review of Prevalence, Impacts, and Interventions. *Journal of Multidisciplinary Research for SMET (JMR-SMET)*, 1(1), 177-183. <https://doi.org/10.64297/jmrsmet.v1i1.19>

- Porter, M. E. (1990). *The competitive advantage of nations*. Free Press.
- Qun, Z. (2023). Opportunities, Challenges and Prospects of China-Asean Digital Economy Industry Cooperation *Journal of International Relations*(3), 43-61.
- Rochet, J.-C., & Tirole, J. (2003). Platform Competition in Two-Sided Markets. *Journal of the European Economic Association*, 1(4), 990-1029. <https://doi.org/10.1162/154247603322493212> %J *Journal of the European Economic Association*
- Secretariat, C. (2024). Opening Remarks on Opening Ceremony of the 21st China-ASEAN EXPO. Nanning International Convention and Exhibition Centre (NICEC).
- Suh, J., & Roh, J. (2023). The effects of digital trade policies on digital trade. 46(8), 2383-2407. <https://doi.org/https://doi.org/10.1111/twec.13407>
- Tao, S., & Zhengyang, Y. (2018). Analysis of the Dynamic Comparative Advantage and Structural Evolution of the Trade in Service between China and Countries along the “Belt and Road”. (1).
- Tinbergen, J. (1963). Shaping the world economy. 5(1), 27-30. <https://doi.org/https://doi.org/10.1002/tic.5060050113>
- van Dijk, J. A. G. M. (2020). *The Digital Divide* [Book]. Polity Press.
- Wei, S., Jidong, Y., & Chunling, Q. (2021). Research on the Competitiveness and Complementarity of Service Trade between China and RCEP Partner Countries: An Analysis from an Industry Perspective *Price Theory and Practice*(03), 15-19. <https://doi.org/https://doi.org/10.19851/j.cnki.cn11-1010/f.2021.03.132>
- Williamson, O. E. (1981). The Economics of Organization: The Transaction Cost Approach. *American Journal of Sociology*, 87(3), 548-577.
- Xinran, W. (2018). Jointly building the 21st Century Maritime Silk Road and constructing the China-Asean Innovation Community. (08), 4-8.
- Xu, S., Shen, R., Zhang, Y., & Cai, Y. (2024). Fostering regional innovation efficiency through pilot free trade zones: Evidence from China. *Economic Analysis and Policy*, 81, 356-367. <https://doi.org/https://doi.org/10.1016/j.eap.2023.12.004>
- Yu, X., & Wei, L. (2023). Research on the Development of China-Asean Digital Trade under the Framework of the Digital Belt and Road Initiative *Journal of Beijing University of Technology (Social Sciences Edition)*, 23(06), 58-81.
- Yuanpeng, Z., & Chaonan, W. (2024). Analysis of China's Long-term and Huge Trade Deficit in Digital Products with ASEAN International trade(08), 65-75. <https://doi.org/https://doi.org/10.14114/j.cnki.itrade.2024.08.008>
- Yubiao, H., & Jianghui, L. (2019). Analysis of the Impact Mechanism of Trade Expos on China's Trade Development: From the Perspective of Platform Economy Theory. *Social Sciences*(08), 46-56. <https://doi.org/https://doi.org/10.13644/j.cnki.cn31-1112.2019.08.005>.

Yuchang, F. (2022). Analysis of the Development and Influencing Factors of China-Asean Digital Service Trade [Master, <https://doi.org/10.27479/d.cnki.gzgcd.2022.000005>].

Zhaokun, Q., & Wensu, Y. (2024). Research on the Efficiency and Potential of China's Digital Service Trade Exports to ASEAN: Chinese Business Theory. 33(20), 68-73. <https://doi.org/https://doi.org/10.19699/j.cnki.issn2096-0298.2024.20.068>.